

# **J**ABM

**JOURNAL of  
ACCOUNTING - BUSINESS & MANAGEMENT**

---

- Reduction of Audit Quality by Auditors of Small and Medium Size Audit Firms in Malaysia: A Case of Premature Sign-Off of Audit Documents**  
Khairunnisa Mohd Jais, Anuar Nawawi and Ahmad Saiful Azlin Puteh Salin 1-12
- Significance of Audit Committee Roles in India: A Study of Auditors' Perception Using Analytic Hierarchy Process**  
Mamta Mishra and Amarjeet Kaur Malhotra 13-20
- Knowledge Management and Its Effect on Strategic Decisions of Jordanian Public Universities**  
Sulieman Ibraheem Shelash Al-Hawary and Abdulazeez Mohammed Alwan 21-41
- Accounting and Financial Systems and Tools for Effective Leadership and Management**  
A. Seetharaman, Nitin Patwa, Veena Jadhav and A. S. Saravanan 42-57
- Innovative Marketing Tools: A Case Study of IDFC Mutual Fund**  
Pooja Sharma and Manisha Gupta 58-65

## Knowledge Management and Its Effect on Strategic Decisions of Jordanian Public Universities

Sulieman Ibraheem Shelash Al-Hawary\*  
Abdulazeez Mohammed Alwani†

---

### Abstract

This study aims to identify the effect of knowledge management on strategic decisions of the Jordanian public universities in the north region. Knowledge management represented (knowledge identification, knowledge generation, knowledge storing, knowledge dissemination, knowledge applying, knowledge evaluation) as independent variable, either the dependent variable was the strategic decisions and its represented by (decision convenience, decision acceptance and decision quality), to measure the variables of the study, the researchers developed a questionnaire and distributed to all managers at various levels of the public universities in the region of north, total (198), and to answer study questions and testing of hypotheses SPSS was used.

The researchers found that knowledge management and strategic decision level was mid, as the results showed a statistically significant effect of knowledge evaluation and knowledge storing on strategic decisions at the Jordanian public universities in the north region.

Researchers recommend the development of incentives and rewards system for its employees effectively and comprehensively for all management staff and to link these incentives with the actual performance of the staff at the university and continue to use the modern technologies and attract qualified personnel and creative and able to roles of knowledge in universities in north region.

**Keywords:** knowledge management, strategic decisions, public universities, Jordan.

---

### I. INTRODUCTION

Recent developments and changes had led to a shift from a focus on money as the most important asset in the organization to knowledge; recruitment of knowledge to serve the goals of the organization become more important and the greatest success measurement; in the past, organizations were focusing on tangible assets as a measure of their market position, and competitiveness, most contemporary organizations their focus became on intangible assets represented by knowledge to build a general rule to their work, and keep up with all new to keep pace with fast-changing business environment.

The capabilities, the expertise, and skills of the human capital not be equal between individuals, there are a group of them have ingredients listed more than others (Al-Rousan & Al-Ajlooni, 2010), hence there is a need for knowledge management

---

\* Professor of Business Management, Department of Business Administration, Faculty of Finance and Business Administration, Al al-Bayt University. P. O. Box 130040, Mafraq 25113, Jordan. Mobile: +96-277-6786819 E-mail: dr\_slیمان73@aabu.edu.jo, dr\_slیمان@yahoo.com.

† Researcher, Department of Business Administration, Faculty of Finance and Business Administration, Al al-Bayt University. P. O. Box 130040, Mafraq 25113, Jordan. E-mail: Abd198866@yahoo.com.

as an indication of the existence of a clear and comprehensive way to understand and invest these components through deregulation limits and restructuring which helps in development and change to cope with the requirements of the economic environment, increase the company's revenue, employees satisfaction and loyalty, and improve their competitive position by focusing on intangible assets. As a result of the failure of knowledge management programs with focus on information technology and information systems that did not focus sufficiently on the human side of knowledge management (Al-Daher, 2009).

Knowledge transformation obtained great importance lately, because it drawn attention to the human element, and its importance within the knowledge management, where knowledge transformation cares to ensure the transfer of knowledge from tacit knowledge into explicit knowledge and vice versa, so that this process will continue within the organization that lead to creativity, thus the transition occurs between individuals in the organization, because each individual or group possess certain knowledge, so organizations should work to convert this knowledge among individuals and groups to utilize in different managerial activities (Al-Hamdani & Al-Hareri, 2008). Human resources in general and knowledge resources in particular play the main role in making strategic decisions and objectives, monitoring and analysis of the external environment and supervise internal operations, and measuring efficiency, in addition it is involved in helping to increase productivity (Bognar & Bansal, 2014).

Organizations must employ all its knowledge in the process of making strategic decisions which are of the most important decisions, that allow organization to keep up with the changes, as it is connected directly with the internal and external environments, so that organizations must recognize the importance of investing in human resources and increasing their knowledge. Thus it is clear that knowledge management is the ability to manage intellectual capabilities of a certain group of human resources, represented by in the competencies which able to generate ideas for creative and strategic development for systems, processes, strategies and activities to ensure that the organization making strategic decisions lead to achieve a sustainable competitive advantage.

Educational institutions especially higher education at present face the stage of radical transformation, due to the pressures of the acceleration changes in educational and technological environment, and competition between universities internationally that spreading in the Arab world, education institutions have tended to grow and increase in number of students, and increase challenges to the introduce modern teaching methods and upgrade overall performance which required to concern with knowledge management operations for the purpose of making strategic decisions.

Knowledge and experience are distributed among individuals in the organizations, and so are vulnerable to extinction and vanishing, so there is an urgent need to collect, and developed and exploited at optimal way, maintenance, conservation, and then publish or manage them to achieve goals that found because of it, so it requires to public universities in the North region represented by (Al al-Bayt University and Al-Yarmouk University and the university of science and technology) employing knowledge management in making strategic decisions that contribute to achieving competitive advantage, their decisions need to be support to strengthen their capabilities to achieve their objectives if they have the necessary knowledge and effective management of this knowledge.

Because of the lack of Arabic studies (according to researcher's knowledge) that connected between knowledge management and strategic decisions in the organizations

management, the researchers seek in this study to identify the extent to which knowledge management in making strategic decisions.

## **II. THEORETICAL FRAMEWORK**

Creation of a culture of knowledge management is required by the organizations, and make radical changes in all managerial regulations affecting human resources in terms of technical skills, work principles, organizational policies, and the behavior of the leader and his traits, he plays the most important role in the success regardless of the difficulty of the work that employees face, to enable organizations look to the future, which is a requirement for those looking for excellence performance. With advanced modern technology revolution, growing competition, organizations became increasingly aware of the importance of knowledge and its role as an activity that can be organized, methodical, to come up with new methods, services to achieve better performance, talking about the benefits of knowledge management confirms that organization really needs these systems for the purpose of carrying out their activities and their effectiveness in order to achieve the goals which want to achieve in all managerial levels, to optimal employ functional knowledge and achieve organizational efficiency, organization need to develop different functions, methods of work and performance in line with the nature of its work, and the massive scientific expand in the technical areas of the information systems has an impact, make decision making easier (Quintas et al., 2012).

Increased attention with knowledge management by the management scientists, this imposes various organizations the need to identify the knowledge they seek, and ways to discover and access, in addition to the methods of use and apply to ensure competition, survival and continuity in a rapidly changing environment (Al-Kubaisi, 2005), which requires successful management, which has been defined as “the process of achieving the set goals by exploiting the available resources within a certain environment”.

### **2.1. Knowledge Management Concept**

Management of knowledge is a contemporary science, but attention to structural knowledge and its relationship with workplace is relatively new, it is worth noting that much has been written about this relationship, but most of it was through the past years, and since the early 1990s. In 1980, in the first American Conference on artificial intelligence, Edward Freignebaum referred to his famous statement “knowledge is power” and since that time it has appeared a new term called “knowledge engineering” with its birth, new functional biography introduced is known as “knowledge engineer”, and in 1997 appeared another new field, the result of perceiving the importance of knowledge in the information era, “knowledge management” (David, 2014).

Knowledge management has become one of the good solutions for organizations in meeting the challenges they face, because knowledge and information are the main assets in organizations that cannot do without, knowledge management is most important source in building competitive advantage, and become the strongest and most influential factor in the success of organizations and enhance competitive position (Al-Shahrani, 2010). Knowledge management is also real and important nerve and input change, which improve the quality of educational institutions today, and are an important resource in creating creativity, as there are some kind of harmony and interdependence between knowledge management and activities of educational institutions (Hamouda, 2010). Organizational knowledge management efforts focus

usually on objectives such as improve performance, competitive advantage, innovation, sharing lessons learned, and continuous improvement, knowledge management is seen as potentially suitable for access to organizational learning (Wiig, 2013).

Wiig (2013, p. 16) defines knowledge management as: “a set of clear and specific processes and approaches towards good objective to discover knowledge jobs, whether positive or negative, in various types of operations, and management, and identification of products or new strategies, and strengthen the management of human resources, and achieve a number of other goals”. Knowledge management concept includes: definition and analysis of available and required knowledge resources, and processes for these resources, planning and control of the actions for the development of resources and operations, and contributing to achieving the objectives of the Organization. Knowledge resources in this context is the knowledge owned by the organization or that need to possess, which related to products, market, technologies and organizations which contribute to increase profits or provide added value to the products and services (Kabir, 2015). Laudon and Laudon (2007) defined knowledge management, it's that process that provides the knowledge for workers in the various sectors through the provision of information and dissemination of knowledge and information. Al-Janabi (2013) indicates that knowledge management as 'a structured process to attract, generate, store, application of knowledge for performance development, learning, and work to improve performance and make appropriate decisions. Al-Osman (2013) notes that knowledge management 'it is the efforts that include a variety of ongoing processes and practices which determine the required knowledge, create, develop, storage, dissemination, and retrieval, which results in higher performance and competitive advantage. Al-Abadi and Al-Baghdadi (2010) defined knowledge management as “a set of operations that their objective from these processes to convert intellectual resources into tangible values, and interest in intangible assets primarily”.

Through the previous definitions, knowledge management may be defined as is a set of processes and activities carried out by the management of organizations to determine the required knowledge and find it, and keep track of the different managerial methods that help on it is management, to invest effectively to create added value to their activities and operations to achieve competitive advantage, and provide an opportunity to survive in an environment characterized by major change and development.

## **2.2. Knowledge Management Process**

Knowledge management is an ongoing process with no specific beginning or end, knowledge management processes are those means by which add value to the raw knowledge of inputs with a view to creating knowledge represented by outputs, the fundamental purpose of knowledge management for the organizations the overall use of existing knowledge, develop creativity, and encourage investment in human resources, this can only be achieved through a set of processes.

Researchers disagree in identifying knowledge management process in eight steps are: knowledge diagnostic, and defining knowledge objectives, knowledge generation, storage, disseminating of knowledge, the application of knowledge, knowledge retrieval, and maintenance knowledge. William (2008) indicates that knowledge process are four steps are to generate knowledge, attract knowledge, knowledge transfer, and knowledge sharing. Hijazi (2005) suggested three processes are generating knowledge, knowledge-sharing, and organizational learning. Bognar and Bansal (2014) address three stages of knowledge management is to generate knowledge, build knowledge, and knowledge

efficiency. Tadros and Abdel Rahman (2014) knowledge management processes consist of the objectives of knowledge, knowledge generation, storing knowledge, knowledge disseminating, organizing knowledge, knowledge retrieval, maintenance knowledge. Al-Zatma (2011) points out that knowledge management processes is to diagnose knowledge, knowledge generation, and store knowledge, knowledge distribution, while Al-Makableh (2013). Suggested three processes of knowledge management are to acquire knowledge, knowledge sharing, and applying knowledge. Abu Fara and Olyan (2011) that knowledge management is a knowledge diagnostic, planning knowledge, update knowledge, dissemination and sharing of knowledge, generation and knowledge acquisition, knowledge storage, retrieval of knowledge, knowledge application, and follow up and control of knowledge. Nasiruzzaman et al. (2013) indicate that knowledge process in two dimensions is explicit knowledge and tacit knowledge, and Parisa and Saied (2015) referred that knowledge management is about knowledge production, sharing of knowledge, knowledge development, and continuous improvement. Tadres et al. (2014) suggested nine stages of knowledge management involves the application of knowledge, identify the goals of knowledge, knowledge generation, storing knowledge, knowledge disseminating, apply knowledge, organize knowledge, knowledge retrieval, and sustaining knowledge.

The researchers noted the diversity of knowledge management process in the previous studies due to different researchers methods and vision about knowledge management and its goals, and the researchers adopted six stages of knowledge management process in their study (knowledge identification, knowledge generation, knowledge storing, knowledge dissemination, knowledge applying, knowledge evaluation).

### **2.2.1. Knowledge Identification**

Knowledge identification is the first step of knowledge management process, and it considered as important, because without knowledge identification we cannot reach the desired level of knowledge required to achieve performance, in the light of the results of the diagnostic process, other programs and policies are developed, the diagnostic process is very important because of their results we get knowledge sites and persons they have knowledge and therefore the success of the organization in achieving performance depends on the accuracy of the results of this process (Probst, 2000).

Knowledge identification represents the first step in the knowledge management process, being determines the quality of the knowledge which the organization wants, identifying its sources and methods of obtaining, knowledge identification process is the key to any program of knowledge management, and substantial process directly contribute to launch other processes and their depth, and users have a high degree of knowledge, but it is possible to generate new knowledge through research and development, experimentation, learn lessons, and collective thinking.

### **2.2.2. Knowledge Generation**

Knowledge generation is to create something new, and this is done by sharing work groups and task forces to generate new knowledge capital in new issues and practices contribute to the identification of problems and find solutions creatively and continuity, as it provides the organization with the ability in excellence achievement and start new business lines and accelerate problem solving, transfer of best practices, and develop the skills of professionals, to assist management in recruiting and retaining talent, and this reinforces the understanding that knowledge and innovation are double process with two ways, knowledge is the source of innovation, innovation becomes

source of new knowledge. Knowledge generation process is a creative process makes the organization outperforms its competitors (Al-Zyadat, 2008).

Nonaka and Takeuchi (2004) refers that knowledge generation process consists of multiple processes that extend between creativity challenge and serious research, and finds that there is another kind of knowledge generation process detected by solving the problem, and through experimentation that have the most value to the organization, individuals are generating knowledge, and knowledge cannot be generated without individuals, and then developed at the group level through dialogue, conversation and sharing of experience.

### **2.2.3. Knowledge Storing**

The process of knowledge storing is done through different ways: the traditional approach which made through traditional records and documents, and modern approach which made through computers, and storage of knowledge in modern scientific method enable organization to retrieve information in times of need. Organizations that suffer from high turnover rates that depend on the use and recruitment of temporary contracts and consulting formula for generating knowledge, because they take with them the implicit knowledge which is undocumented, Documented knowledge is stored in the Organization (Al-Batayneh & Al-Mshakbh, 2010).

Al-Kubaisi (2002) referred that in order to work on sharing knowledge, you should pay attention to three fundamental points are: share the knowledge switched us from individual work to group work, then the difference in the style and nature of participation varies depending on the type of knowledge, and finally knowledge sharing is different from information sharing, because the information does not include thinking.

### **2.2.4. Knowledge Dissemination**

Knowledge dissemination is the process of distributing knowledge within the organization, and it is the first step of knowledge sharing, knowledge distribution means the delivery of appropriate knowledge to the right person at the right time, in the appropriate form, and at the right cost, as the process of knowledge dissemination is the knowledge transfer for employees who are in need to benefit in the core processes, means intake of ideas and experiences between employees, and this requires the communication process with workers and use what they know to solve problems, knowledge grows when it is shared and used (Dalkir, 2005).

Al-Batayneh and Al-Mshakbh (2010) indicates that share and distribute knowledge is important process in improving the creativity and organizational performance down to a learning organization, through promoting on research and development, and distribution what they have reached through teams and groups, which contributes to the generation of ideas and innovations between teams and groups, providing a means of communication, and distribution channels by using all kinds of networks in the desired time, with the promotion of a culture of collaboration and knowledge sharing, the distribution process is not an easy process, especially the distribution of knowledge within the organization, and between departments to achieve a competitive advantage for the Organization among other organizations.

### **2.2.5. Knowledge Applying**

The knowledge application process is the last and most important stage of knowledge management processes, knowledge management is the application of knowledge available in the organization, and to apply knowledge in individual and group learning processes, that lead to invent new knowledge, and hence the naming of

knowledge management processes as closed loop, several methods are used to apply knowledge, as internal experience, multiple teams, and work initiatives, and proposals of internal expert, and the adoption of control measures over knowledge, and training with experts. Knowledge application is the main source to achieve organization's goals and purposes that seek, the purpose of knowledge management is to invest in knowledge, to obtain and store knowledge and participation alone is not enough but it is important to transfer this knowledge to implement (Alkhiro et al., 2004).

### **2.2.6. Knowledge Evaluation**

Knowledge evaluation process represented in two essential dimensions: explicit knowledge and takes the form of specific rules and procedures to perform job efficiently and achieve performance and the ability in doing business, and this type is evaluated through performance appraisal systems and some through accounting systems, while the second dimension represents in tacit knowledge, and this dimension is not subject to performance evaluation and accounting systems, because tacit knowledge is intangible asset may be high or low and be harder than the first dimension to be evaluated (Al-Arabi, 2009).

Knowledge evaluation process provide obtaining information from sources, and how to handle it, because they contribute to the sustainability of the organization and achieving organizational economy, so the good economy is through good management of resources, and this applies on knowledge management which includes organizational management, organizational knowledge management and intellectual capital management and these types connected to each other in order to achieve the organizational vision (Minonne & Turner, 2014).

### **2.3. Strategic Decision**

The term of strategy are commonly used in management books, and originated to a Greek word (Strategos) which means the art of war and battle management, as some researchers see that the strategy is a plan, and some of them see strategy means something important and others think it is a designed program to success and excellence, strategy is considered as a part of the strategic planning and the path to be chosen from among multiple paths to achieve organizational goals and achieve the direction in which the organization seeks to be in the future (Hanna, 2012).

Researchers agree that effective strategic planning and efficient strategy serve as a magic wand in performance improvement, especially since we live in an age with many challenges as a result of rapid scientific and technical developments, and in light of these challenges, the traditional management is unable to compete, making organizations use all possible methods to enable them to compete, the researchers found that strategic management represents an intellectual approach characterized by modernity and entrepreneurial, organization can through it able to compete and seek to develop their performance and makes it distinct From other organizations (Al-Qahtani, 2010).

### **2.4. The Concept of Strategic Decision**

Al-Shammari (2006) defined strategic decisions as decisions which take a future nature and reflect what the organization wishes to achieve in the future, and provides a framework for making decisions at lower levels. Slack et al. (2004) defined strategic decisions as those decisions used by senior management to achieve organization's success, over the long term and it needs to allocate resources to achieve adaptation with important situations.



Al-Dahabi and Al-Azzawi (2005) defined strategic decisions as decisions that relate to the organization as a whole, and relates to the long term goals and plans, and depends on application of substantive plans and achieve goals, taking into account all the possibilities and future attitudes. Al-Aref (2005) finds that “strategic decisions are specific job which relates to senior management and sometimes called strategic planning”.

As Al-Salem (2005) defined strategic decisions as decisions of several qualities of which non-repeated, long-term, characterized by scarcity, and used in light of unconfirmed information. Researchers find that strategic decisions is one of the most important means used to reach goals and objectives, serves as a unified plan connect between parts of the organization and be comprehensive covering all activities of the organization, and be integrated and homogeneous access to the organization’s goals.

## **2.5. Measurements of Effective Strategic Decisions**

**Decision convenience:** effective strategic decision is that decision that suits the internal organization conditions, and external conditions, the more information is available to the decision maker, clear, and accurate whenever more effective strategic decision, here comes the role of strategic decision support systems, which is about a computer program that depend organization upon to get a good location between competitors, and the ownership of strategic information systems is an essential condition for the success of organizations in the current era, the attention by top management began because they help in building strategic decisions more convenient, what goes on inside and outside the organization in bringing about rapid changes than invited to seek to obtain new data and processed in the form in which the decision maker can obtain knowledge about the dimensions of the problem, and reversed the lack of information and knowledge about the dimensions of the problem leads to make strategic decision costly, so that today, organizations have increased interest in those systems (Al-Sharabi, 2008).

**Decision acceptance:** decision acceptance process is extremely important, for the successful implementation of the decisions, and the only way to achieve acceptance by involving employees in the decision process, the decision to be more important, so must use method of participation that guide in decision making and effective strategic decision process, and help to create a positive atmosphere stimulates change and create an impetus and incentive for employees, and promote participation of mutual trust between top management and employees by expanding the channels of communication between them., And also participation provides information and ideas on a given topic, and achieve optimal investment of workers ' skills and abilities, as contribute to solving problems, which is the first step to build an acceptable and realistic strategic decisions (Olema, 2007).

**Decision quality:** decision quality representing the ability to provide several alternatives and options, with the ability to create new ideas and evaluating and measuring the validity of the decision, as well as determine the suitability and a decision to be obtained, as experience considered as the best source for high quality strategic decision, and then enable the organization to build competitive advantage, being intangible things are difficult for competitors to obtain, it can be said that the strategic decision maker and what he possess of abilities and distinctive capabilities have the greatest impact on understanding the dimensions of the problem, and having skill considering alternatives and multiple options at the same time, and can access the best alternative choice and high quality compared to other alternatives (Husseini, 2012).

## 2.6. Knowledge Management and Strategic Decision

Knowledge management has an important and effective role in strategic decisions, the decision making process is complex and requires significant support, the decision maker does not make decision directly, but is based on the knowledge available to him within the organization, and this knowledge is known decision support systems, decision support systems can be defined as those systems that identify, classify and diagnose required facts and tie them together and then used in developing decision, It can be said that strategic decisions need to be supported to the level up is known strategic decision, decision support systems depend primarily on the knowledge base, with the knowledge base, knowledge management can add success in making the decision, the decision maker is due to the knowledge stored in knowledge bases for a good strategic decision (Al-Doury, 2004).

The knowledge factor is the most important factor in the decision making and its effectiveness, some researchers indicate that knowledge factor features is unique in its nature among other factors, because it is the central of realizing interesting (environment) and adopting response (option), strategic behavior forms the organization's survival technique, knowledge factor on of the techniques that describes compatibility and intellectual harmony, and it's one of the constraints to effective strategic decision. The existence of knowledge factor and group thinking process refer on how to integrate information in strategic decision making mechanism, where most strategic decisions are group decisions and not individual decisions, because it determine the future of the organization, the structure of group work through which the decisions are decided is an important variable to determine whether knowledge factor will contribute in a positive way in the decision making process.

Al-Zrekat (2011) noted that there is an impact of knowledge management dimensions on the effectiveness of the decision in the Jordanian extractive companies. Also Al-Douri and Al-Shamari (2004) noted that knowledge management plays an important and effective role on strategic decision making in industrial organizations and employ them in the process of building and making strategic decisions.

## III. RESEARCH HYPHOTHESES

Based on the above literature reviewed, the research hypothesis is:

**H<sub>1</sub>**: knowledge management directly influences strategic decisions of Jordanian public universities.

More specifically:

**H<sub>1a</sub>**: knowledge identification directly influences strategic decisions of Jordanian public universities.

**H<sub>1b</sub>**: knowledge generation directly influences strategic decisions of Jordanian public universities.

**H<sub>1c</sub>**: knowledge storing directly influences strategic decisions of Jordanian public universities.

**H<sub>1d</sub>**: knowledge dissemination directly influences strategic decisions of Jordanian public universities.

**H<sub>1e</sub>**: knowledge applying directly influences strategic decisions of Jordanian public universities.

**H<sub>1f</sub>**: knowledge evaluation directly influences strategic decisions of Jordanian public universities.

#### IV. RESEARCH FRAMEWORK

Based on study hypothesis, the following theoretical framework, shown in Figure 1. As can be seen from the framework, the study investigates the impact of knowledge management on strategic decisions of Jordanian public universities., where knowledge management process are the independent variable and are positively related to strategic decisions as the dependent variable.

**Figure 1**

##### Theoretical Model

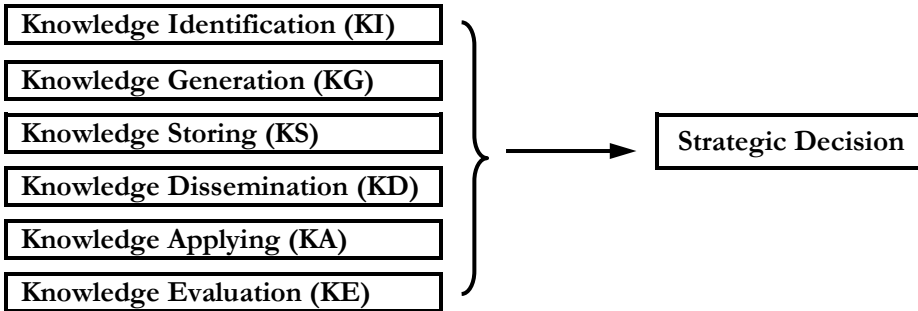

#### V. METHODOLOGY

The methodology section of the current research depicts the sample of the study, the measurements, the statistical analysis to test the validity and reliability of the study tool, and to test the study hypotheses employed to test the relationship between study constructs (knowledge management process and strategic decisions).

##### 5.1. Data Collection

Data are collected using a questionnaire. The questionnaire was divided into three sections: Section A consisted of a list of questions intended to probe the demographic variables of the respondents. Section B contained questions aimed at gauging the respondents' evaluation of knowledge management process adoption by Jordanian public universities adopted from previous studies, and which could possibly influence strategic decisions, using a five-point Likert scale. The following dimensions were focused on; knowledge identification (5 statements), knowledge generation (5 statements), knowledge storing (5 statements), knowledge dissemination (5 statements), knowledge applying (5 statements), and knowledge evaluation (5 statements). Section C is also adopted from previous studies, contained questions aimed at evaluating the strategic decisions made by Jordanian public universities were focused on; decision convenience (5 statements), decision acceptance (5 statements), and decision quality (5 statements).

A pretest was carried out with six professors of management and information system to determine the validity of the content of the survey questionnaires. In the main survey study, a total of 160 questionnaires were distributed to the managers of public universities at different levels. A cover letter was attached together with the survey questionnaire. The cover letter described the aim of the study, guaranteed anonymity of data, requested the respondent to answer each question.

##### 5.2. Measures

The constructs in this study were developed by using measurement scales adopted from prior studies. Modifications were made to the scale to fit the purpose of the study. All constructs were measured using five-point Likert scales with anchors

strongly disagree (= 1) and strongly agree (= 5). All items were positively worded. Knowledge management process consist of knowledge identification, knowledge generation, knowledge storing, knowledge dissemination, knowledge applying, knowledge evaluation were adapted from previous studies (Tadros & Abdel Rahman, 2014; Ibrahim & Iman, 2014). Strategic decisions construct consist of decision convenience, decision acceptance, and decision quality were adapted from previous studies (Oleamat, 2007; Al-Sharabi, 2008; and Hussein, 2012).

### 5.3. Operational Definitions

**Knowledge management:** a system consists of a set of processes, designed to generate, identify, organize and store all kinds of knowledge within the university, and make it ready for exchange and sharing between individuals and departments within the university to achieve efficiency in decisions.

**Knowledge identification:** the process of identifying policies, programs and operations for the Jordanian public universities in the Northern territory, and see what types of knowledge available, and who has knowledge and their sites.

**Knowledge generation:** Means all operations carried out by public universities in Northern Territory in order to obtain knowledge with different methods and sources.

**Knowledge storing:** refers to the process of developing knowledge of organizational memory of the Jordanian public universities in the territory North to become available for everyone, to keep them and use them quickly if need be.

**Knowledge disseminating:** refers to the process of knowledge exchange between individuals at the Jordanian public universities in Northern territory, through horizontal and vertical lines of communication, this done through workers by sharing knowledge in a friendly manner to meet the objectives of sharing between them and the university, such as employee sought to acquire specific expertise and sought university to benefit from this experience.

**Knowledge application:** refers to processes of use and reuse and benefit from the knowledge available through application in organizational units of university.

**Knowledge evaluation:** a set of actions adopted by the Jordanian public universities in the North territory to the extent to which they benefit from knowledge and sources and what requirements needed to expand the use of knowledge.

**Strategic decisions:** decisions taken by the university about the organization and its relationships with individuals and their environment, and characterized by relatively stable, long term and made by top management.

### 5.4. Sample

The study population consisted of all the heads of units, sections and departments in Jordanian public universities in the North region (198), the researchers has made several visits to the public universities in the North region of Jordan (3) universities (Al al-Bayt University and Al-Yarmouk University and the University of science and technology), and the researcher again visited the managerial units and distributing the study tool on the managers at all levels mounted (160). Subjects were asked to assess their perceptions of various items of different constructs. Assessments were based on a five-point Likert scale ranging from “strongly disagree (1) to strongly agree (5)” was used to measure the 45 items. In order to minimize possible response bias, instructions emphasized that the study focused only on their personal opinions. (150) questionnaires retrieved. After reviewing the questionnaires show that there are (4) extremely unfit for statistical analysis, that had the study sample size (146).

**Table 1**  
**Sample Characteristics**

Variable	Frequency	%	
<b>Age group</b>	Less than 25	3	2.1
	25- less than 35	26	17.8
	35- less than 45	60	41.1
	45 years and more	57	39.0
<b>Gender</b>	Male	114	78.1
	Female	32	21.9
<b>Educational level</b>	Diploma	10	6.8
	Bachelor	71	48.6
	High Diploma	8	5.5
	Master	49	33.6
	PhD	8	5.5

Females make (21.9 percent) of the customers on the other hand Males respondents represented (78.1 percent) of the survey population. The largest group of respondents (30.2 percent) were aged 40- less than 50. The next largest group (41.1 percent) were aged 35- less than 45 years. Smaller groups of respondents were aged less than 25 (2.1 percent). With regard to educational level, respondents with Bachelor degrees were the largest group of respondents make (48.6 percent), respondents with diploma degrees make (6.8 percent). Respondents with master degrees make (33.6percent). Respondents with high diploma degrees make (5.5 percent). Finally, holders of PhD degrees make (5.5 percent) of the managers. The sample characteristics of the respondents represented in Table 1.

### 5.5. Reliability and Validity of the Survey Instrument

The survey instrument with 45 items was developed based on two variables knowledge management as independent variables with six dimensions: knowledge identification (KI1-KI5), knowledge generation (KG1-KG5), knowledge storing (KS1-KS5), knowledge dissemination (KD1-KD5), knowledge applying (KA1-KA5), and knowledge evaluation (KE1-KE5). Strategic decisions as dependent variables with three dimensions: decision convenience (DC1-DC5), decision acceptance (DA1-DA5), and decision quality (DQ1-DQ5).The instrument was evaluated for reliability and validity. Reliability refers to the instrument's ability to provide consistent results in repeated uses (Gatewood & Field, 1990). Validity refers to the degree to which the instrument measures the concept the researcher wants to measure (Bagozzi & Phillips, 1982).

Insert Table 2 and 3 here.

Factor analysis and reliability analysis were used in order to determine the data reliability for the knowledge management process, and strategic decision measures. A within factor, factor analysis was performed to assess convergent validity. The results of the factor analysis and reliability tests are presented in Table 2 and Table 3. All individual loadings were above the minimum of 0.5 recommended by Hair et al. (1998). For exploratory research, a Chronbach  $\alpha$  greater than 0.70 is generally considerate reliable (Nunnally, 1978). Chronbach  $\alpha$  statistics for the study contracts are shown in Table 2 and Table 3. Thus it can be concluded that the measures used in this study are valid and reliable. On the basis of Cattell (1966) and Hair et al. (1998) criterion, factors with eigenvalues greater than 1.0 and factor loadings that are equal to or greater than 0.50 were retained. 45 items, loading under six factors of knowledge management and three factors of strategic decision.

**Table 2**  
**Factor Analysis of Knowledge Management Process**

<b>Construct and Item</b>	<b>Loading</b>	<b>Communalities</b>	<b>Eigenvalue</b>	<b>Variance</b>	<b>Reliability</b>
<b>Knowledge identification (KI):</b>			3.021	58.232	0.78
KI1	0.38	0.63			
KI2	0.59	0.55			
KI3	0.66	0.58			
KI4	0.71	0.76			
KI5	0.64	0.62			
<b>Knowledge generation (KG):</b>			2.984	68.222	0.76
KG1	0.70	0.75			
KG2	0.75	0.72			
KG3	0.73	0.68			
KG4	0.71	0.75			
KG5	0.79	0.74			
<b>Knowledge storing (KS):</b>			2.764	62.312	0.79
KS1	0.86	0.71			
KS2	0.85	0.75			
KS3	0.85	0.70			
KS4	0.86	0.76			
KS5	0.86	0.67			
<b>Knowledge dissemination (KD):</b>			2.879	53.811	0.86
KD1	0.58	0.77			
KD2	0.75	0.56			
KD3	0.64	0.68			
KD4	0.73	0.76			
KD5	0.70	0.61			
<b>Knowledge dissemination (KA):</b>			2.643	62.212	0.85
KA1	0.64	0.74			
KA2	0.63	0.74			
KA3	0.76	0.63			
KA4	0.70	0.70			
KA5	0.86	0.69			
<b>Knowledge evaluation (KE):</b>			2.776	60.111	0.86
KE1	0.67	0.76			
KE2	0.61	0.73			
KE3	0.64	0.68			
KE4	0.76	0.70			
KE5	0.73	0.73			

**Table 3**  
**Factor Analysis of Strategic Decision**

Construct and Item	Loading	Communalities	Eigenvalue	Variance	Reliability
<b>Decision convenience (DC):</b>			3.216	56.354	0.94
DC1	0.526	0.642			
DC2	0.631	0.748			
DC3	0.548	0.642			
DC4	0.572	0.661			
DC5	0.627	0.728			
<b>Decision acceptance (DA):</b>			2.910	62.574	0.84
DA1	0.549	0.614			
DA2	0.511	0.597			
DA3	0.564	0.583			
DA4	0.618	0.751			
DA5	0.605	0.721			
<b>Decision quality (DQ):</b>			2.785	67.389	0.84
DQ1	0.507	0.543			
DQ2	0.581	0.624			
DQ3	0.564	0.597			
DQ4	0.523	0.568			
DQ5	0.622	0.719			

### 5.6. Descriptive Statistics Analysis

Table 4 indicates that managers of Jordanian public universities in the region of the north evaluate knowledge identification (with the highest mean scores, i.e. M= 3.80, SD= 0.62) to be the most dominant of knowledge management process and evident to a considerable extent, followed by knowledge storing (M= 3.66, SD= 0.57), knowledge evaluation (M= 3.38, SD= 0.65), knowledge applying (M= 3.33, SD= 0.69), knowledge dissemination (M= 3.31, SD= 0.80), and knowledge generation (with the lowest mean scores M= 3.20, SD= 0.66). With regard to strategic decisions managers of Jordanian public universities in the region of the north perceived decision acceptance (with the highest mean scores, i.e. M= 3.55, SD= 0.77) to be the most dominant strategic decisions dimension within their institution and evident to a considerable extent, followed by decision convenience (M= 3.50, SD= 0.70), and decision quality (with the lowest mean scores M= 3.45, SD= 0.66).

**Table 4**  
**Descriptive Analysis of Knowledge Management and Strategic Decisions**

Dimension	Mean	Standard Deviation
<b>Knowledge management:</b>	<b>3.44</b>	
Knowledge identification (KI)	3.80	0.62
Knowledge generation (KG)	3.20	0.66
Knowledge storing (KS)	3.66	0.57
Knowledge dissemination (KD)	3.31	0.80
Knowledge applying (KA)	3.33	0.69
Knowledge evaluation (KE)	3.38	0.65
<b>Strategic decisions:</b>	<b>3.50</b>	
Decision convenience (DC)	3.50	0.70
Decision acceptance (DA)	3.55	0.77
Decision quality (DQ)	3.45	0.66

## VI. TEST OF HYPOTHESIS

Multiple regression analysis was employed to test the hypotheses. It is a useful technique that can be used to analyze the relationship between a single dependent variable and several independent variables (Hair et al., 1998). In this model, strategic decisions acts as the dependent variable and knowledge management process, as the independent variables. From the result as shown in Table 5, the regression model was statistically significant ( $F= 44.50$ ;  $R^2= 0.65$ ;  $P= .000$ ). The  $R^2$  is 0.65, which means that 65.0 percent of the variation in strategic decisions can be explained by knowledge identification, knowledge generation, knowledge storing, knowledge dissemination, knowledge applying, knowledge evaluation. The proposed model was adequate as the F-statistic= 44.50 was significant at the 5% level ( $p<0.05$ ). This indicates that the overall model was reasonable fit and there was a statistically significant association between knowledge management and strategic decisions.

Table 5 also shows that knowledge storing ( $p<0.05$ ;  $\beta= 0.37$ ), and knowledge evaluation ( $\beta= 0.36$ ,  $p<0.05$ ), had a significant and positive effect on strategic decisions. This provides evidence to support  $H_{1c}$  and  $H_{1f}$ . Based on the  $\beta$  values knowledge storing has the highest impact on strategic decisions followed by knowledge evaluation with regard to knowledge identification, knowledge generation, knowledge dissemination, and knowledge applying based on their  $\beta$  values were not supported.

**Table 5**

### Regression Results Between Knowledge Management and Strategic Decisions

Independent Variables	Standard-ized Beta	t	Sig.	Tolerance	VIF
<b>Knowledge identification (KI)</b>	0.10	1.38	0.17	0.45	2.20
<b>Knowledge generation (KG)</b>	0.05	0.64	0.52	0.35	2.83
<b>Knowledge storing (KS)</b>	0.37	5.87	0.00	0.68	1.48
<b>Knowledge dissemination (KD)</b>	0.03	0.31	0.76	0.28	3.58
<b>Knowledge applying (KA)</b>	0.14	1.42	0.16	0.24	4.24
<b>Knowledge evaluation (KE)</b>	0.36	4.66	0.00	0.41	2.45

**Notes:**  $R^2= 0.65$ ; Adj.  $R^2= 0.64$ ; Sig.  $F= 0.000$ ; F-value= 44.50; dependent variable, strategic decisions ;  $p<0.05$

## VII. DISCUSSION, RECOMMENDATIONS AND DIRECTION FOR FUTURE RESEARCH

### 7.1. Discussion

1. With regard to knowledge management, the results of the study showed that the primary goal of the university is to acquire and deploy the maximum amount of knowledge and information, and Jordanian universities make efforts to diagnose knowledge to get information from the most basic cognitive dimensions that can be exercised through the application of knowledge management, as it helps the university to change and achieve desired growth in its cognitive capacity over time. Diagnosing knowledge of the most important processes in any software for knowledge management, their impact on other operations policies within the same program, and in the light of consciousness of universities towards the importance of diagnosis knowledge and the impact of its results in diagnosing the types of knowledge in the university, to process definition knowledge identification contribute to the university to work within the framework of a structured intellectual capable of understanding and comparison between current knowledge



assets and required knowledge assets, which contributes to make the university cope with the changes of modern knowledge. knowledge generation is concerned with the intellectual side of the knowledge management functions, which concerned with the human side, universities are seeking to bring the human element capable of generating knowledge, whether from inside or outside the university. As well as public universities seeking to master the methods of storing knowledge and identifying knowledge sources according to their importance to the staff, so that university work on building information resources development policy, building knowledge resources evaluation policy, purification and objective analysis of the sources of knowledge.

2. Knowledge disseminating in public universities depend on technology to use and reuse, which makes their application depends mainly on the use of the university for technology in the field of knowledge, as the results of the study showed that the application of knowledge in public universities in Jordan requires training sessions, and dialogue permit its application within the university, and the researchers attribute this result to the application process which may encounter some obstacles which represented by lack of experience, resistance to change, lack of culture and language barrier. Besides knowledge evaluation in need for indicators to measure knowledge management in the university in order to carry out the evaluation, to determine whether it is best to complete the implementation of specific policy in the same manner, or make changes to reach the goals set.
3. Regarding knowledge management; researchers found that people responsible for the decision-making processes in public universities do not take into account the connection between a series of strategic processes and decisions that take years, and can be explained in that decision makers in public universities in the northern territory do not set the strategies and decisions to deal with urgent matters to respond to unexpected events as they happen. Public universities interested in collecting relevant information for strategic decisions, because convenience is broad concept requires understanding of quantitative and qualitative information. Add to that the acceptance of university workers to the decision, and potential excitement represents one of the most important prerequisites for their commitment to accept the decision, defend and support.
4. The study found a statistically significant effect of knowledge management process on strategic decisions, as the value of the correlation coefficient ( $R= 0.81$ ), and it is a statistical significant, and indicate the degree of statistical significant correlation between the independent variables and the dependent variable, and the value of ( $R$ -square= 0.65) and the value of the coefficient of determination (Adjusted  $R$  square= 0.64) is a statistical significant values, explain the ability of knowledge management process to influence strategic decisions, in the sense that knowledge management explain (64%) of the change in strategic decisions. This result can be explained in that public universities in the Northern territory, after increasing numbers of private university in Northern territory seeks to ensure its survival and continuity, so they are working on employing knowledge management and make it a feature for their performance, as the researcher attributed this result to upper management awareness in public universities in the Northern territory towards the importance of applying knowledge management as an effective tool in increasing the effectiveness of the workers performance, and can explain this result is that the knowledge management process in universities increase effectiveness of strategic decisions, as they help to optimum use of the information, facilitate managerial procedures, and

increase efficiency among its workers, and that this result is that the application of knowledge management helps the university to upgrade its scientific and management output equally. This result agreed with study Tadros and Abdel Rahman (2014) which indicated that the level of knowledge management in Al-Balqa' applied university from the viewpoint of administrators of middle management and top management was with medium degrees, and study of Al-Zrekat (2011) which showed that there is an impact of knowledge management process on the decision effectiveness of the extractive companies.

5. The results showed a statistically significant effect of knowledge identification on strategic decisions at public universities in Northern Territory, this result can be explained is that public universities after growing numbers of private university in Northern Territory seeks to ensure its survival and continuity of the powerful and influential works on employing knowledge management and make it a feature for performance, but that interest has not affected to the extent required for strategic decisions. The results also showed a statistically significant effect of knowledge generation on strategic decisions at public universities in Northern Territory from the point of view of heads of departments, and units managers, which can explained is that the interest in the generation of knowledge in universities did not reach the threshold required to actively influence strategic decisions, as they help to optimum use of the information and facilitate administrative procedures and increase efficiency among employees.
6. Results showed a statistically significant effect of knowledge storing on strategic decisions at public universities in the North region, the researcher attributed this result to that public universities seeking to enhance their store of knowledge by making it a key factor in either academic or managerial levels, so that universities seek to promote ways to use, share, and exchange ideas and experiences among staff through formal or informal communications, which contributing to convey a clear picture of the information and data thus raising the efficiency and appropriateness of the decisions taken at the university. The results also showed a statistically significant effect of knowledge disseminating on strategic decisions at public universities in the North region, the researcher attributed this result to that public universities do not work on knowledge disseminating in increasing opportunities for worlds for participation in strategic decision-making, which make these decisions more receptive for employees, because of what contained properties which important to them.
7. The results showed a statistically insignificant effect of knowledge application on strategic decisions at public universities in the North region, the researcher attributes this result to lack of interest of departments at the universities in Northern Territory to the importance of accuracy and reliability of information in the strategic decisions, so that knowledge management application provides the decision maker with accurate, complete, relevant and comprehensive information and data resolution, which contributes to raising the quality of decision. The results also showed a statistically significant effect of knowledge evaluation on strategic decisions of public Jordanian universities in Northern Territory, this result attributed to the searcher s is that public universities do not employ knowledge evaluation just only regarding upgrading their scientific and management outputs.

## 7.2. Recommendations

Based on the findings of the study, the researchers offer a set of recommendations for management and decision makers of public universities in the North region, the researcher aims behind these recommendations to contribute to the improvement and development of knowledge management in universities of Jordan to achieve effective management of knowledge, of these recommendations:

1. Develop a system of incentives and rewards for their employees effectively and comprehensively for all managerial cadres and linking these incentives with the actual performance of employees in the university.
2. Training courses at public universities in the Northern Territory to persuade employees to exchange information, experiences and knowledge among them; to increase knowledge sharing and knowledge generation in the university.
3. Continue to use modern technologies and attract qualified, and creative personnel and able to roles defined in Northern Territory universities.
4. Take advantage of existing scientific competencies at the university in promoting knowledge management applications.
5. Attention to the disseminating and application of knowledge and dissemination of brochures on knowledge management concept and its importance and its role in achieving the goals of the university.

## 7.3. Direction for Future Research

Researchers find that there are many areas where researchers can do their study to go through further research in order to contribute to their research on detection of variables or other results contribute to the enrichment of knowledge in knowledge management and strategic decisions, where studies to detect the impact of knowledge management on other variables such as job satisfaction, creativity and excellence, they can study to detect the impact of information technology development on knowledge management in Jordanian universities.

## REFERENCES

- Abu Fara, Y., & Olyan, H. (2011). *The role of knowledge management on effective activities of institutions in East Jerusalem*. Unpublished master's thesis, Al-Quds University, Jerusalem, Palestine.
- Al Osman, A. A. M. A. (2013). *The reality of applying knowledge management in Naif for security sciences*. Unpublished master's thesis, Naif for Security Sciences, Riyadh.
- Al Qahtani, F. M. M. A. (2010). *Strategic management to improve the competitive capabilities of companies in accordance with strategic performance standards and total quality management*. Unpublished master's thesis, British International University.
- Al-Abadi, H. F., & Al-Baghdadi, A. H. (2010). *Organizational learning and learning organization and its relationship with contemporary management concepts*. Amman: Al-Waraq Institution.
- Al-Arabi, F. (2009). *The impact of knowledge management in enhancing organizational performance: an empirical study on Jordanian pharmaceutical manufacturers*. Unpublished master's thesis, University of Al al-Bayt.
- Al-Aref, N. (2005). *Strategic Management* (13). University House for Publishing and Distribution.
- Al-Batayneh, M., & Al-Mshakbh, Z. (2010). *Knowledge management between theory and practice*. Oman: Dar Jalees Al-zaman.

- Al-Dahabi, J. M., & Al-Azzawi, N. A. (2005). *Principles of public administration a comprehensive and strategic perspective* (I). Baghdad: Al-Jazeera to Prepare & Print.
- Al-Daher, N. I. (2009). *Knowledge management*. Irbid, Jordan: Modern Book Talk World.
- Al-Douri, M. S., & Al-Shamri, I. A. (2004). *Knowledge management and its role in the promotion and management of vital strategic decisions*. Paper presented at the Fourth Annual Scientific Conference. University of Al-Zaytona, Jordan.
- Al-Doury, A. A. G. O. (2004). *Knowledge management and its role in making strategic decisions: An empirical study on a sample of mixed industrial sector organizations*. Unpublished master's thesis, Mustansiriyah University, Baghdad.
- Al-Hamdani, N. I., & Al-Grgri, A. H. (2008). Effect of knowledge transfer into some functional policies of human resources management: Pilot study in some industrial companies in Nineveh. *The development of Al-Rafden*, 30(19), 111-135.
- Al-Janabi, A. S. (2013). *Knowledge management in building the core competencies*. Oman: Al-Waraq for Publishing & Distribution.
- Alkhiro, Q. S. A., & Jalal, S. (2004). *The impact of knowledge management components on managerial leadership process, analyzing a sample of administrative leaders at Al-Mansour company*. Paper presented at 4<sup>th</sup> Annual Conference, Faculty of Economics and Administrative Sciences, University of Al-Zaytona, Jordan.
- Al-Kubaisi, S. (2005). *Knowledge management*. Cairo: Arabic Organization for Administrative Development Publications.
- Al-Kubaisi, S. A. I. (2002). *Knowledge management and its impact on organizational innovation a pilot study compared a sample of companies in the industrial sector*. College of management and economics, University of Baghdad .
- Al-Rousan, M. A., & Al-Ajlooni, M. M. (2010). Impact of intellectual capital on creativity in Jordanian banks (field study). *Damascus University Journal of Economics*, 26(2).
- Al-Salem, M. S. (2005). *Essentials of strategic management*. Amman: Wael Publishing & Distribution.
- Al-Shahrani, A. S. (2010). *Employing knowledge management in the development of educational institutions*. Unpublished master thesis. King Saud University, Riyadh.
- Al-Shammari, I. A. (2006). Knowledge management and its role in enhancing the strategic decision making process. *Journal of Baghdad College of Economic Sciences*, 11.
- Al-Sharabi, F. (2008). *Management information systems*. Amman, Jordan: Osama's House for Publishing & Distribution .
- Al-Zatma, N. (2011). *Knowledge management and its impact on excellence performance applied study on the intermediate technical colleges and institutes operating in the Gaza Strip*. Unpublished master's thesis. Islamic University, Palestine
- Al-Zrekat, K. K. (2011). Impact of knowledge management in effective decision making in the extractive companies. *Administrative Sciences Journal*, 38(2).
- Al-Zyadat, M. (2008). *Contemporary trends in knowledge management*. Amman: Dar Al-Safa for Publishing & Distribution .
- Bagozzi, R. P., & Phillips, L. W. (1982). Representing and testing organizational theories: A holistic construal. *Administrative Science Quarterly*, 27(3), 459-489.
- Barclay, D. W., Thompson, R. & Higgins, C. (1995). The partial least squares (PLS) approach to causal modeling: Personal computer adoption and use an illustration. *Technology Studies*, 2(2), 285-309.
- Bognar & Bansal (2014). *Knowledge management as the basis of sustained high performance*. United States of America.

- Cattel, R. B. (1966). The scree test for the number of factors. *Multivariate Behavioural Research*, 1(1), 140-161.
- Dalkir P. (2005, January-February). The information executives truly need. *Harvard Business Review*. Retrieved from: <http://www.createadvantage.com/knowledge/bibliography>.
- David, H. (2014). The relations among quality management system, knowledge of the Hekman two-step method. *Journal of Applied Economics & Business Research*, 4, 235-245.
- Gatewood, R. D. & Field, H. S. (1990), *Human Resource Selection*. Chicago, IL: The Dryden Press.
- Hair, J. F. Jr., Anderson, R. E., Tatham, R. L., & Black, W. C. (1998). *Multivariate Data Analysis* (5<sup>th</sup> ed.). Upper Saddle River, New Jersey: Prentice-Hall International.
- Hamouda, K. (2010). *Knowledge-based organization* (1). Jordan: Dar Al-Safa for Publishing & Distribution.
- Hannah, F. (2012). Strategic management application requirements from the perspective of members of the teaching staff at the Faculty of education. *Damascus University Journal*, 28(4).
- Hijazi, H. (2005). *Knowledge management application approach* (1). Amman, Jordan: Al-Ahlia for Publishing & Distribution .
- Hussein, A. A. A. (2012). The impact of information technology in enhancing the effectiveness of strategic decisions, a field study on a sample of commercial banks in Karbala. *Iraqi Scientific Academic Journal*, 8(32), 287-311.
- Laudon & Laudon, J. (2007). *Essentials and management Information system*. Upper Saddle River, New Jersey: Prentice Hall, Inc. Ltd.
- Makableh, Y. Z. (2013). *The impact of knowledge management on innovation management in Jordanian industrial organizations in the Hassan industrial city*. Unpublished master's thesis. University of Al Al-Bayt, Jordan
- Minonne, C., & Turner, G. (2014). Evaluating Knowledge Management Performance. *Electronic Journal of Knowledge Management*, 7(5), 583-592. Retrieved from <http://www.ejkm.com>.
- Nasiruzzaman, M., Qudaih, H. A., & Dahlan, A. R. A. (2013). Project success and knowledge management (KM) practices in Malaysian institution of higher learning (IHL). *Journal of Education & Vocational Research*, 4(5), 159-164.
- Nonaka, I., & Takeuchi, H. (2004). *Hitotsubashi knowledge management*. Singapore: John Wiley & Sons, Asia, Pte., Ltd.
- Nunnally, J. C., & Bernstein, I. H. (1994). *Psychometric theory* (3<sup>rd</sup> ed.). New York: McGraw Hill.
- Olema, S. N. (2007). *The managerial processes in educational institutions*. Amman, Jordan: Dar El Shorouk for Publishing & Distribution.
- Parisa, G., & Saied, S. (2015, January). Relationship between knowledge management and quality management in insurance companies. *International Journal of Academic Research*, 7(1), 475.
- Probst, G. (2000). *Knowledge management*. John Wiley & Sons,
- Quintas, P., Lefere, P., & Jones, G. (2012). Knowledge management: A strategic agenda. *Long Range Planning*, 30(3), 80-89.
- Slack, N., Shuart, C., Stuart, R., & Johnnston, R. (2004). *Operation Management*. (4<sup>th</sup> ed.). New York: Prentice Hall.

- Tadros, I. H., & Abdel Rahman, I. J. (2014). The level of knowledge management practice in Al- Balqa' Applied University from the viewpoint of administrators working in middle and top management. *Journal of Educational & Psychological Sciences*, 15(1).
- Wiig, K. (2013). *Knowledge management foundations thinking about thinking*. USA: Schema Press.